

▶ ELM SERIES MIST ELIMINATOR AIR FILTERS

- Ultra low pressure drop reduces energy costs
- Positive gasket seals eliminate media bypass
- Filter change out differential 170 mbar (2.5 psi)
- True Air/Oil Separator
- Long service life

Applications Include

- Capturing oil fog, mist, or smoke from exhaust and pressure unloading vents on oil flooded compressors, vacuum pumps and blowers
- Any application requiring Low Delta P coalescing of large air volumes
- Vacuum Freeze Drying
- Vacuum Out-Gassing and Vacuum Coating
- Food Processing
- Nailers/Staplers
- Industrial Vacuum Processes
- Cement & Paper Processing

Design

Mist Eliminators are designed to meet the demand for:

- Efficient removal of oil-mist carryover from piston or oil flooded rotary compressors
- Long service life
- Protection from oil slugs or compressor Air/Oil separator failure

Features

- Very low pressure drop
- High oil removal efficiency
- Easy field changing
- Positive sealing O-rings
- Temperature (continuous) 4°C (40°F) min. 80°C (176°F) max.
- Auto Float Drain is standard
- Multiple drain style options available
- Pressure rating of 14 bar (200 psi)
- Removal of particles down to 0.01 micron including coalesced liquid water and oil, providing a maximum remaining oil aerosol content of 0.01 ppm
- Increased surface area in a given volume allows low velocity separation of ultra fine oil mist
- Elements are grounded to canister, minimizing static electricity problems

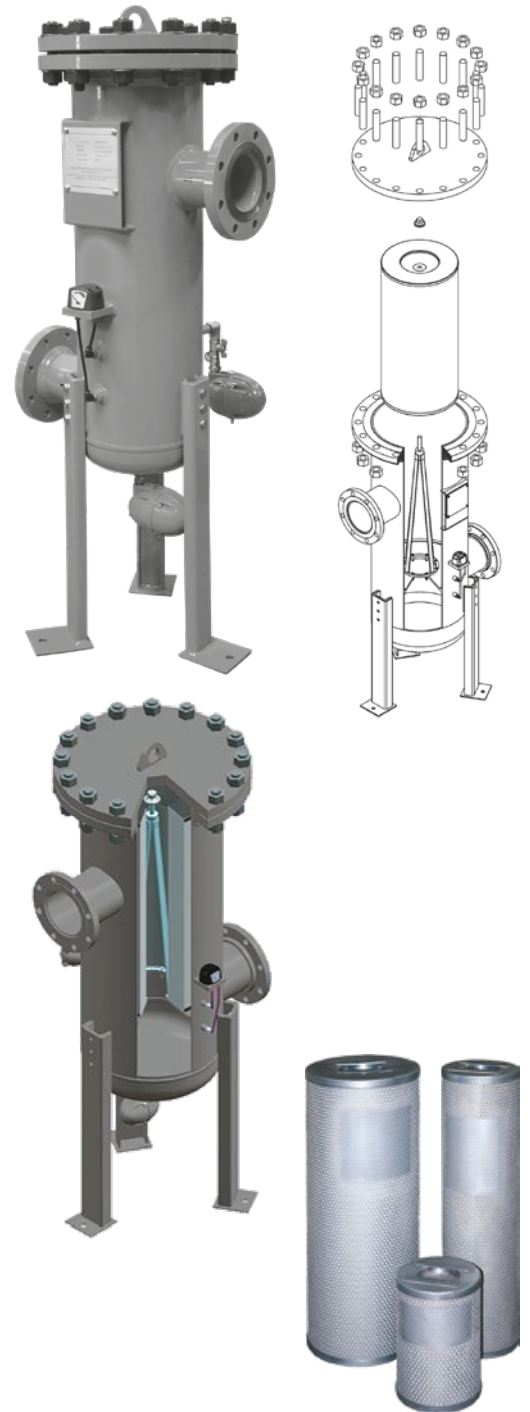

Correction Factor

For maximum flow rate, multiply model flow rate show in the above table by the correction factor corresponding to the working pressure.

Operating Pressure (bar)	PSI	Correction Factor
1	15	0.5
3	44	0.71
5	73	0.87
7	100	1
9	131	1.12
11	160	1.22
13	189	1.32
14	200	1.38

Drain Type
Electro - Adjustable
External Float Type
Zero-loss Drain
Manual

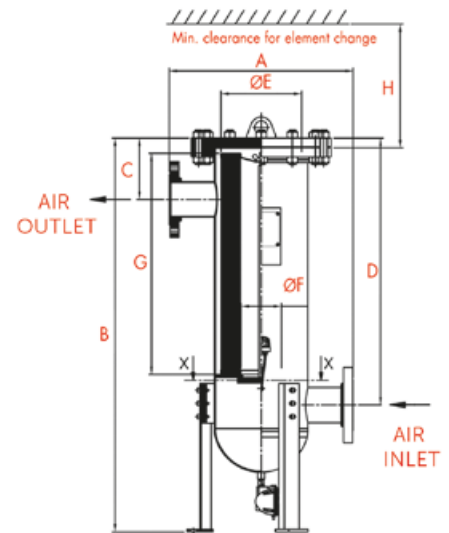
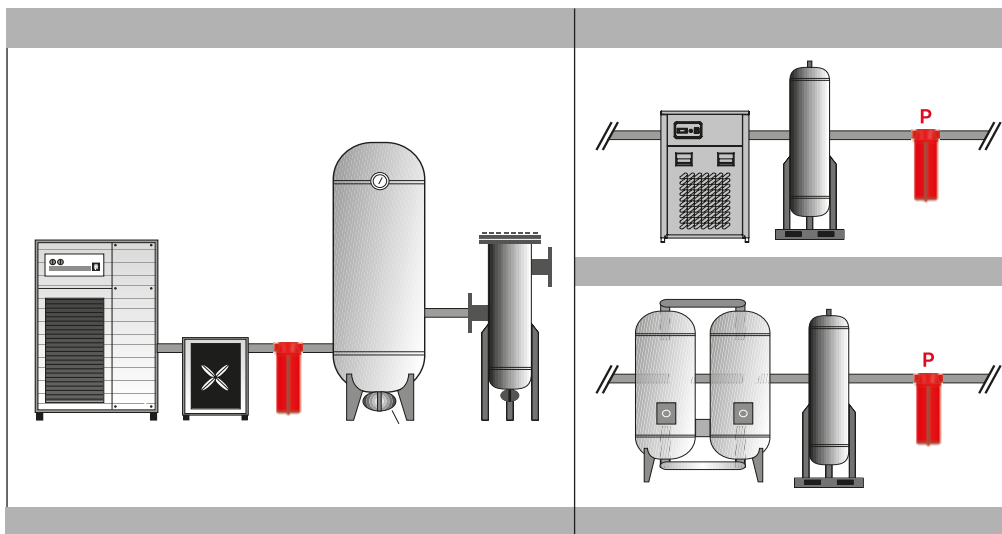

Technical Specifications

Model	Drain Port Size	Inlet/Outlet Port Size	Flow Rate		Max. Working Pressure (bar)	Housing Dimensions (mm)							
			(m ³ /h)	(cfm)		A	B	C	D	ØE	ØF	G	H
ELM-150	1/2"	DN50	255	150	14	500	1003	209	459	203	103	305	330
ELM-300	1/2"	DN50	510	300	14	500	1105	209	559	203	103	407	435
ELM-600	1/2"	DN50	1020	600	14	500	1461	209	916	203	103	762	790
ELM-800	1/2"	DN80	1360	800	14	500	1655	279	1084	203	103	915	950
ELM-1200	1/2"	DN80	2040	1200	14	600	1520	281	931	254	103	762	790
ELM-1600	1/2"	DN80	2720	1600	14	600	1671	281	1086	254	103	915	950
ELM-2100	1/2"	DN100	3570	2100	14	700	1575	335	953	300	129	762	790
ELM-2750	1/2"	DN100	4675	2750	14	700	1726	335	1100	300	129	915	950
ELM-4200	1/2"	DN150	7140	4200	14	800	1670	393	983	365	181	762	790
ELM-6000	1/2"	DN150	10200	6000	14	800	1925	393	1238	365	181	950	1045
ELM-8000	1/2"	DN200	13600	8000	14	850	2020	417	1277	386	233	1016	1045
ELM-10000	1/2"	DN250	17000	10000	14	1000	2118	417	1307	407	337	1016	1045
ELM-12000	1/2"	DN300	20400	12000	14	1000	2688	497	1847	437	337	1524	1550

Given flows are at 7 barg pressure with reference to 20°C and 1 bar atmospheric air suction as per ISO7183.